

# ACTUATOR LA30

## Features:

- 12/24V DC permanent magnet motor
- Max. thrust up to 6000 N (LA30LK)
- Stainless steel piston rod
- Elegant and compact construction with small installation dimensions
- Protection class: IPX0 / IP66
- Colour: black
- Speed max. 65 mm/s (LA30 S-motor with 12 mm pitch)
- Low noise level
- Steel construction for all bearing parts
- Acme thread spindle for optimum efficiency

## Options:

- Extra powerful motor (S-motor)
- L-motor for system actuator
- IP66 (by ordering LA30 with plastic housing)
- Double-acting brake - increased self-locking ability (LA30 with 6 or 9 mm pitch + LA30 S-motor with 6 or 9 mm pitch and LA30L) which ensures that all these types are fully self-locking
- Potentiometer for positioning the actuator 0-1 K ohm, 0-5 K ohm or 0-10 K ohm
- Reed switch (only LA30 L-motor versions): 8 pulses pr. spindle revolution
- Mechanical spline function. Safety feature by using the mechanical spline, the actuator can only push
- Safety nut (only in push)
- Terminal cover (only LA30 L-motor versions)
- Ball screw (K) (only LA30 L-motor versions)
- Ball screw and safety nut (KAS) (only LA30 L-motor versions)
- Ball screw, safety nut and splines (KSM) (only LA30 L-motor versions)

## Usage:

- Duty cycle: Max. 10% or 6 min/hour at continuous use
- Ambient temperature +5° to +40°C
- Storage temperature -40° to +70°C
- Compatible with control boxes CB8, CB12,
- Should LA30 be used with a non LINAK control unit, please ask the nearest LINAK representative for further details



CARELINE<sup>®</sup>  
IMPROVING EFFICIENCY  
TECHLINE<sup>™</sup>  
IMPROVING FLEXIBILITY

LA30 is a powerful actuator yet small enough to fit to most applications. The actuator can be supplied with options such as built-in potentiometer for servo operation or an extra powerful motor for increased speed and strength (S-motor). In addition to industrial and agricultural applications, the actuator is also ideal for positioning satellite dishes.

**Dimensions:**

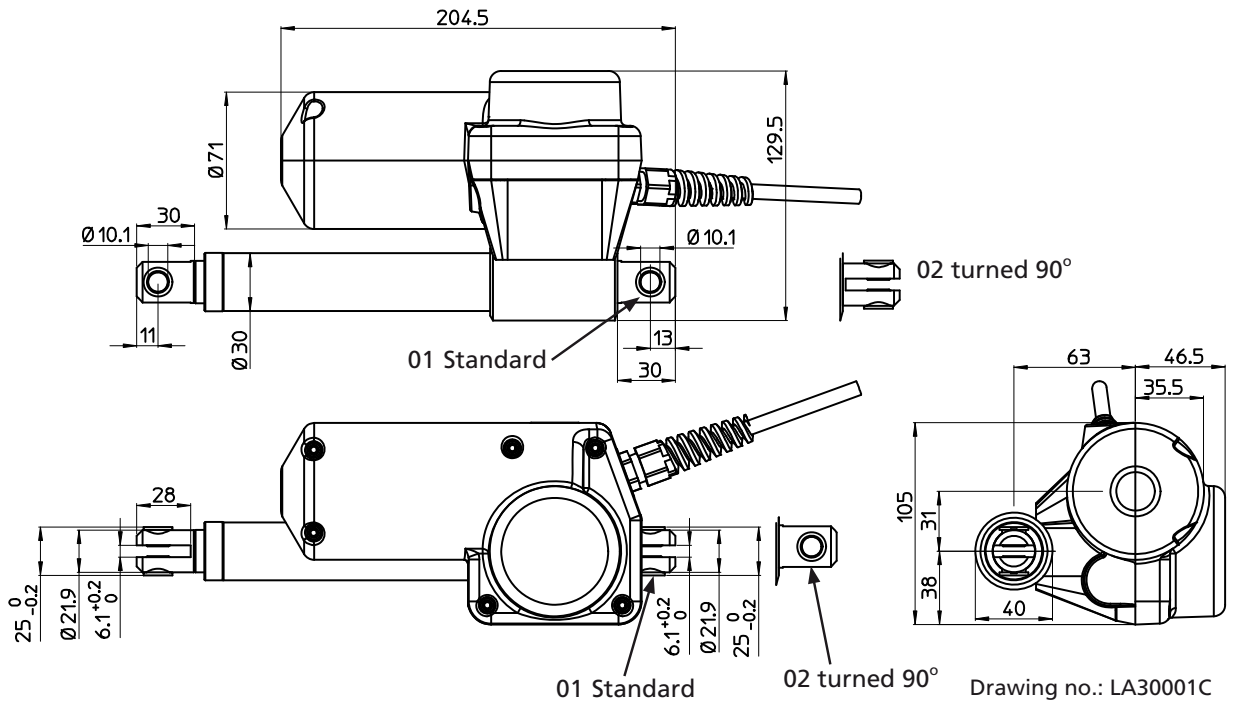

**LA30 with housing mounted with LSD (protection class IPx4)**

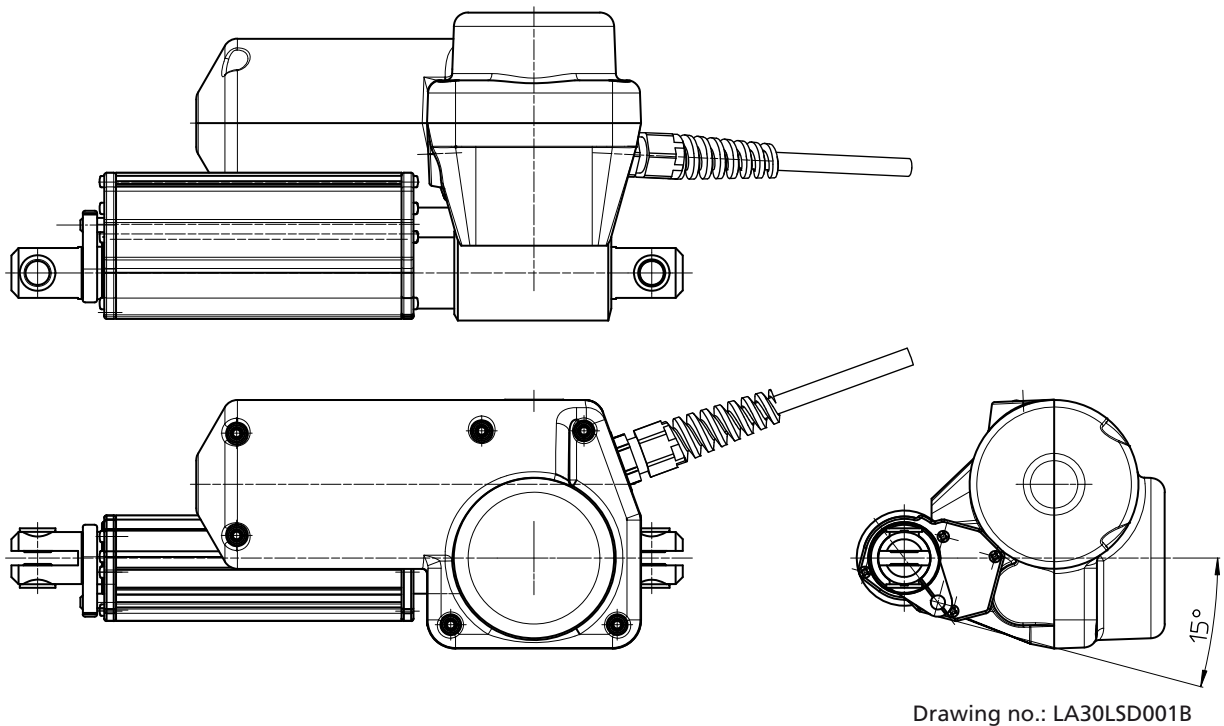

**Installation dimension:**

LA30 L-motor + LA30 + LA30 S-motor with 3 or 6 mm pitch	S + 156 mm
LA30 with spline + LA30 S-motor with 9 mm pitch	S + 167 mm
LA30 with brake + LA30 S-motor with 3 or 6 mm pitch with brake	S + 189 mm
LA30 with ball screw and L-motor / LA30 ball screw and safety nut	S + 194 mm
LA30 L-motor with brake + LA30 S-motor 9 or 12 mm pitch with brake	S + 199 mm
LA30 L-motor with ball screw, safety nut and spline	S + 251 mm

# LA30

## Ordering example:

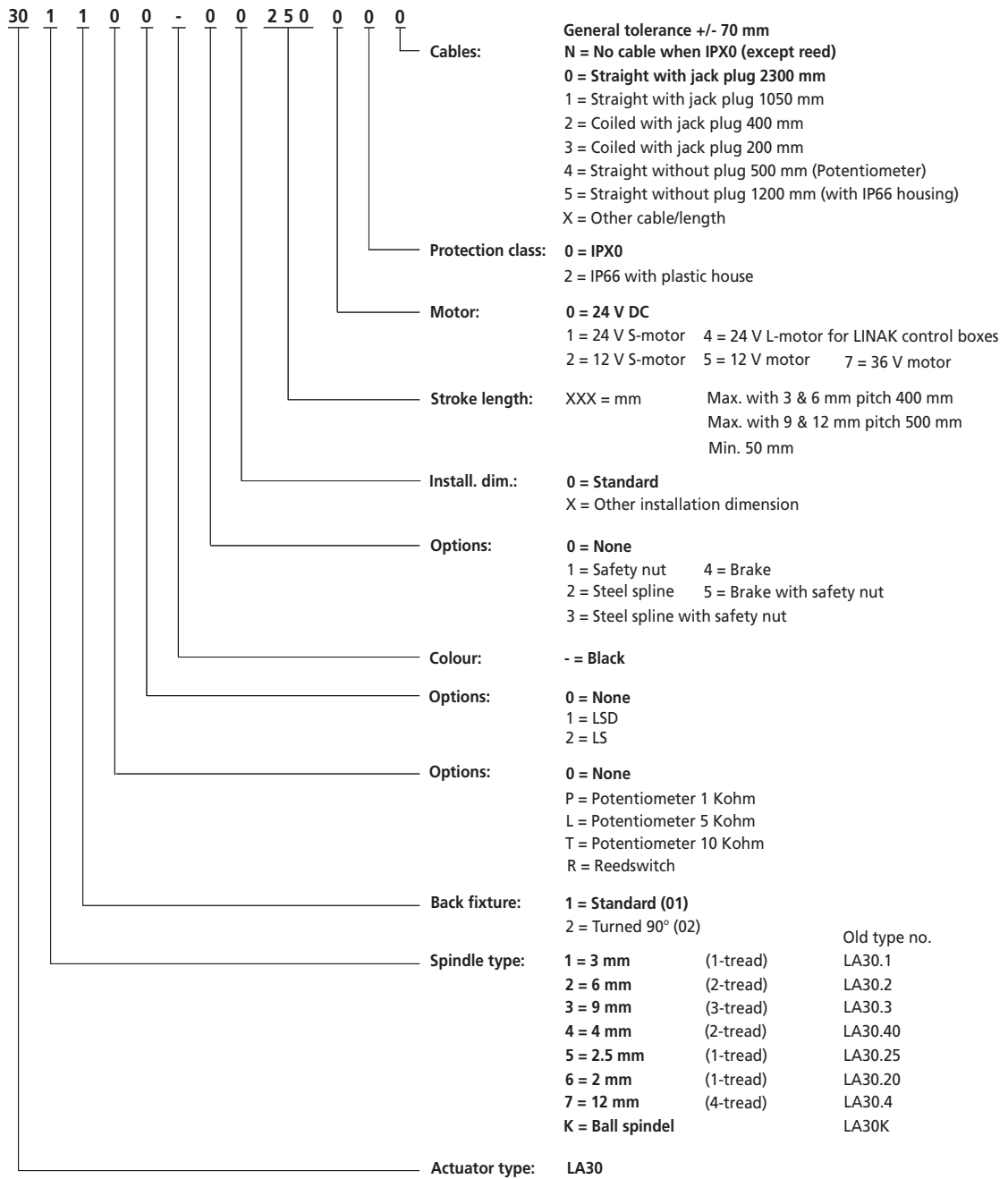

Please note when standard stroke lengths are ordered together with LS / LSD the actuator stroke length will typically be 6 mm shorter and the installation dimension 3 mm longer.

Speed and current graphs:

LA30 24V motor current v's load

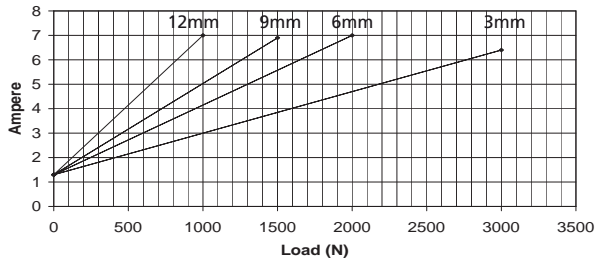

LA30 24V motor speed v's load

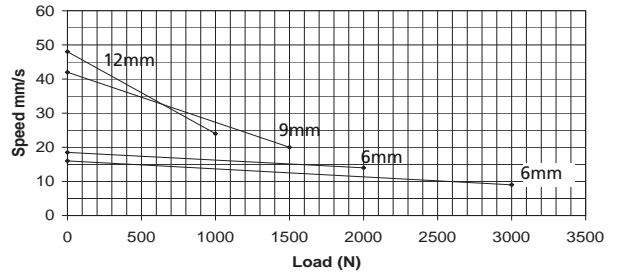

LA30 24V S-motor current v's load

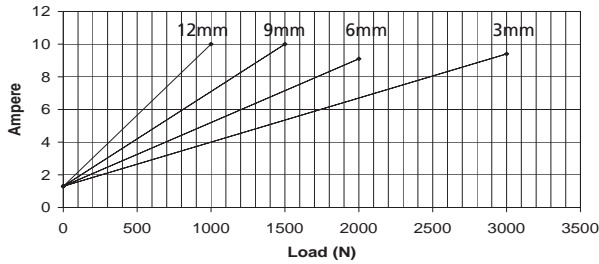

LA30 24V S-motor speed v's load

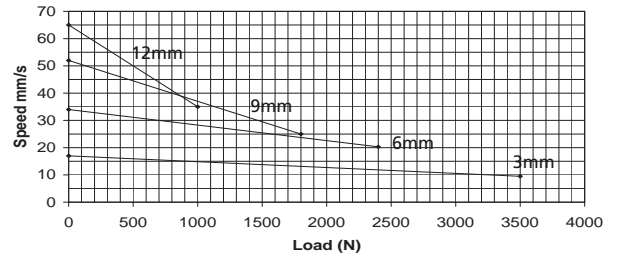

LA30 24V L-motor current v's load

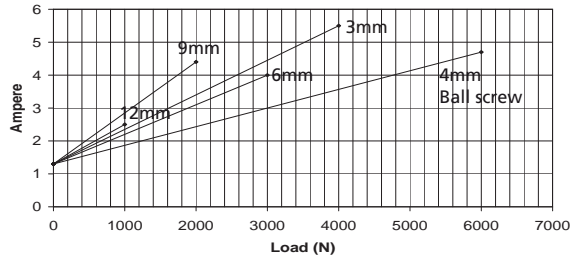

LA30 24V L-motor speed v's load

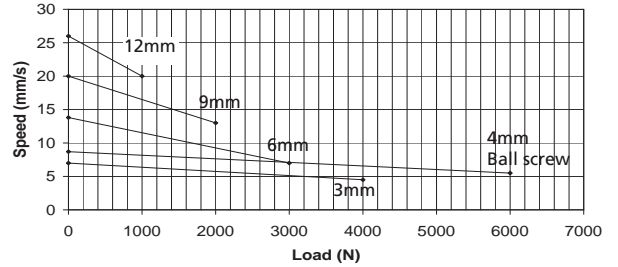

LA30 12V motor current v's load

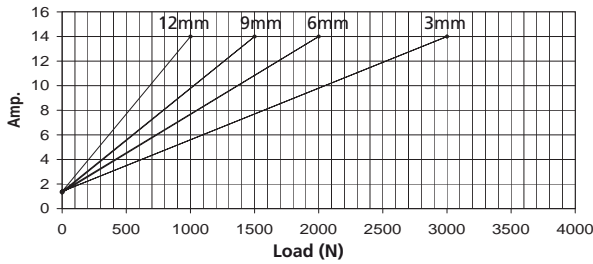

LA30 12V motor speed v's load

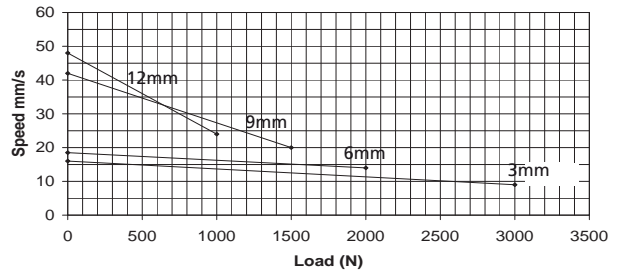

LA30 12V S-motor current v's load

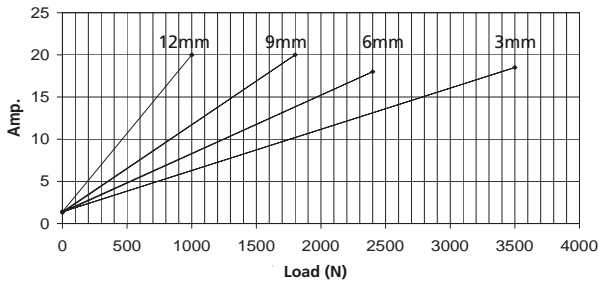

LA30 12V S-motor speed v's load

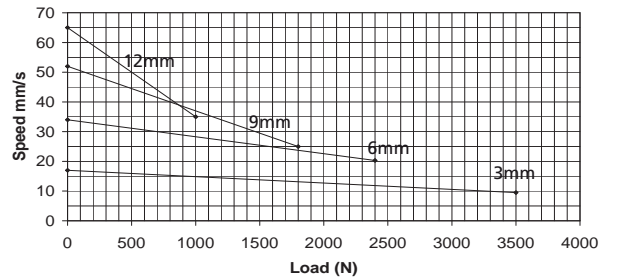

**Technical specifications:**

New type	Spindle pitch (mm)	Thrust max. Push (N)	Thrust max. Pull (N)	*Self-lock max. With/without brake (N)	Typical speed 0/ full load (mm/s)	Stroke length									Typical amp. at full load	
						(mm)									12V	24V
						50	100	150	200P	250	300	350	400P			
307xx0-4xxxx0/5xx	12	1000	1000	1000/0	48/24	50	100	150	200P	250	300	350	400P	14	7	
303xx0-4xxxx0/5xx	9	1500	1500	1500/400	42/20	50	100	150P	200	250	300P	350	400	14	7	
302xx0-4xxxx0/5xx	6	2000	2000	2000/500	18.5/14	50	100P	150	200P	250	300	350	400P	14	7	
301xx0-xxxxx0/5xx	3	3000	3000	3000/3000	16/9	50P	100P	150	200P	250	300	350	400	14	6.4	
307xx0-4xxxx1/2xx	12	1000	1000	1000/0	65/35	50	100	150	200P	250	300	350	400P	20	10	
303xx0-4xxxx1/2xx	9	1800	1800	1800/0	52/25	50	100	150P	200	250	300P	350	400	20	10	
302xx0-4xxxx2xx	6	2000	2000	2000/500	34/20.3	50	100P	150	200P	250	300	350	400P	18	-	
302xx0-4xxxx1xx	6	2400	2400	2400/500	34/20.3	50	100P	150	200P	250	300	350	400P		9	
301xx0-xxxxx1/2xx	3	3500	3000	3500/3500	17/9.5	50P	100P	150	200P	250	300	350	400	18	9	
307xx0-4xxxx4xx	12	1000	1000	1000/0	26/20	50	100	150	200P	250	300	350	400P	-	2.5	
303xx0-4xxxx4xx	9	2000	2000	2000/0	20/13	50	100	150P	200	250	300P	350	400	-	4.4	
302xx0-4xxxx4xx	6	3000	3000	3000/2000	13.8/7	50	100P	150	200P	250	300	350	400P	-	4	
301xx0-xxxxx4xx	3	4000	3000	4000/4000	7/4.5	50P	100P	150	200P	250	300	350	400	-	5.5	
30Kxx0-0xxxx4xx	4	6000	3000	6000/n/a	8.7/5.5	-	-	150	200	250	300	350	400	-	4.7	
30Kxx0-1xxxx4xx	4	6000	3000	6000/n/a	8.7/5.5	-	-	150	200	250	300	350	400	-	4.7	
30Kxx0-3xxxx4xx	4	6000	3000	6000/n/a	8.7/5.5	-	100	150	200	250	300	350	400	-	4.7	

The above measurements are made with the actuators connected to a stable power supply, LA30 L-motor versions with a CB12.

S = Strong motor; L = Slow motor; K = Ball screw; KAS = Ball screw, safety nut; KSM = Ball screw, safety nut, spline.

All stroke lengths marked with "P" give full resolution with the standard potentiometer (1; 5 or 10Kohm). A potentiometer may be used with other stroke lengths but will not give full resolution.

**LA30 Actuator with potentiometer**

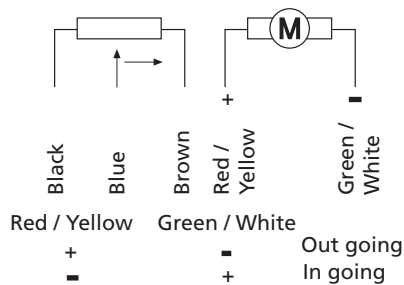

**LA30 Actuator with optical encoder**

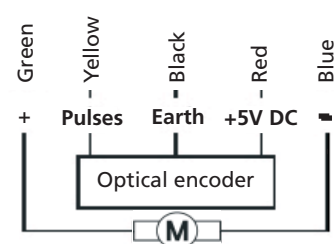

**LA30 Actuator with reed (only possible with 24V L-motor)**

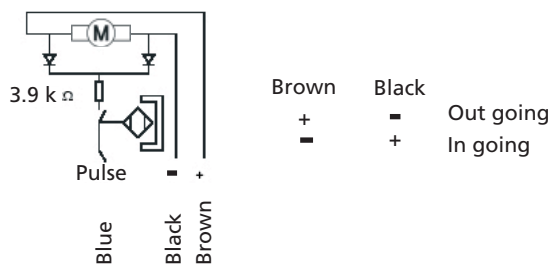

Please note that the voltage level of feedback signal depends on the actuator load.

**Thrust v's Duty cycles for LA30 3 mm pitch**

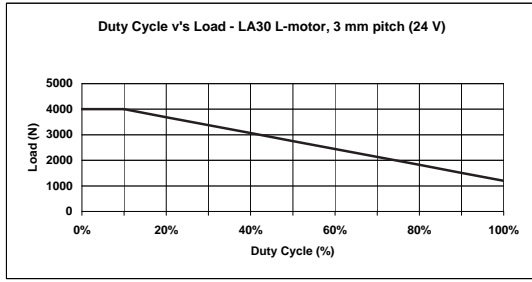

**Thrust v's Average cycles for LA30 3 mm pitch**

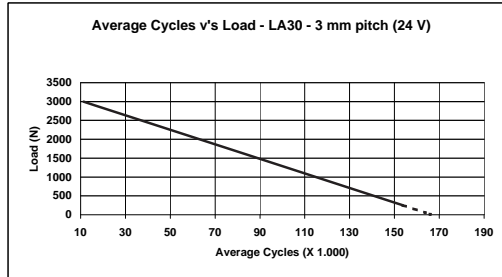
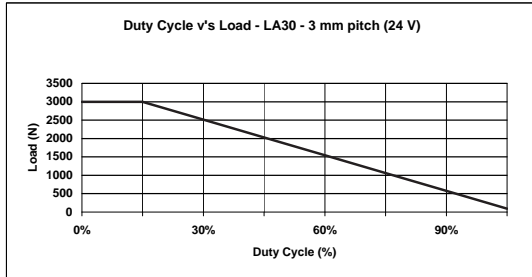
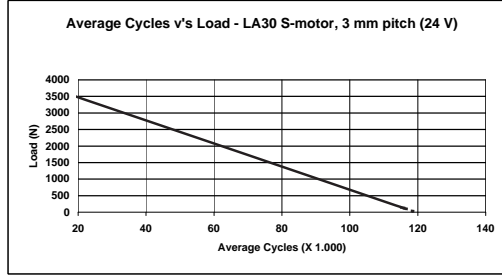
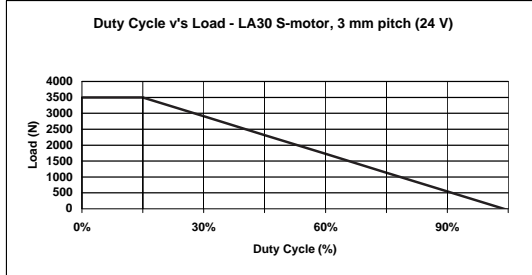
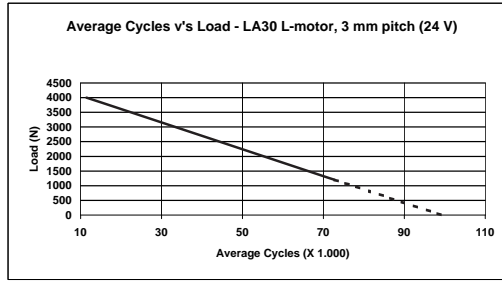

**Thrust v's Duty cycles for LA30 6 mm pitch**

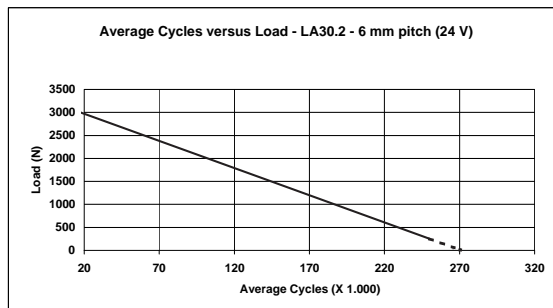
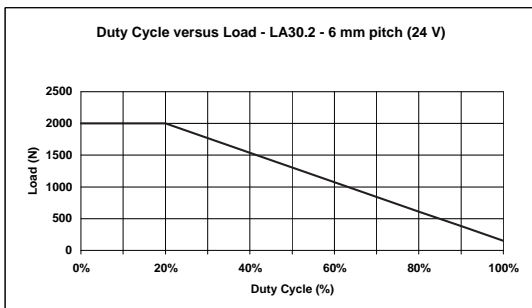
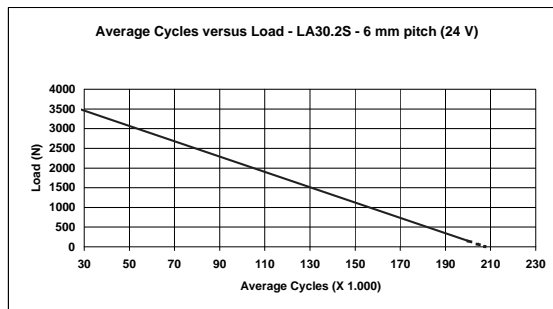
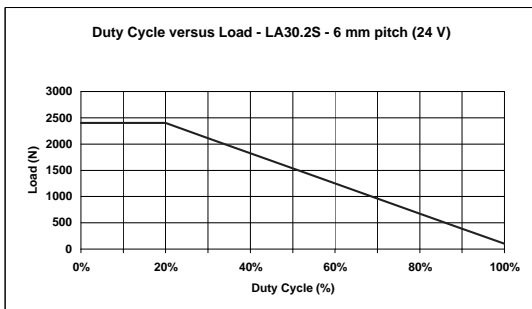
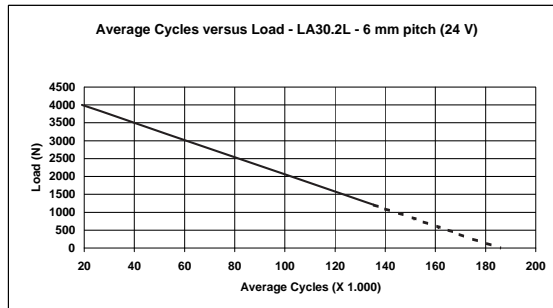
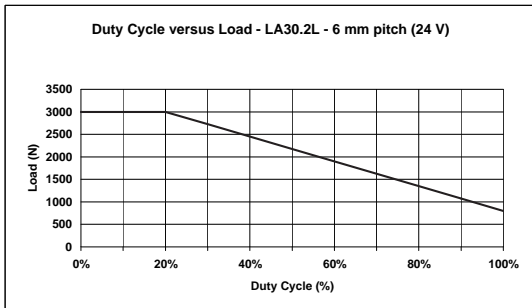

Note: The dashed lines are estimated values only.

### Thrust v's Duty cycles for LA30 9 mm pitch

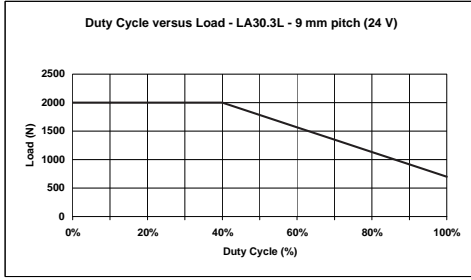

### Thrust v's Average cycles for LA30 9 mm pitch

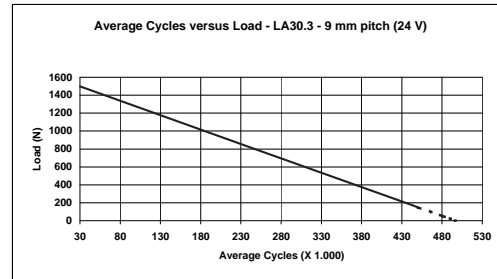
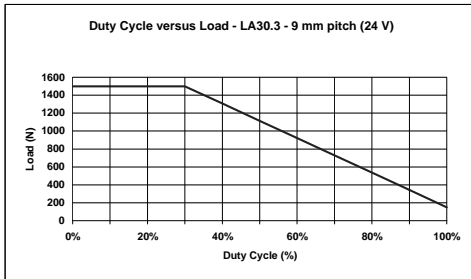
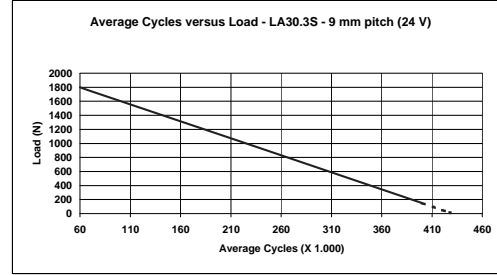
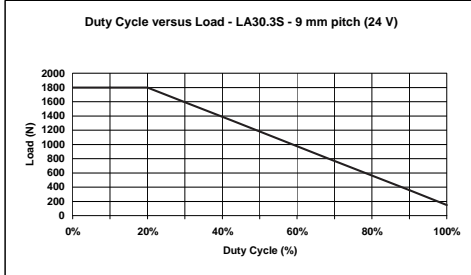
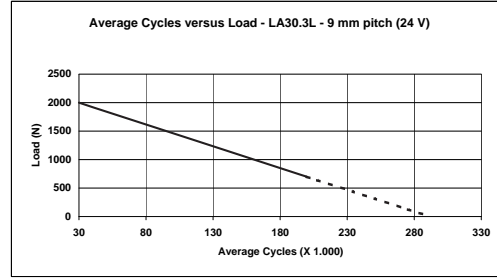

### Thrust v's Duty cycles for LA30 12 mm pitch

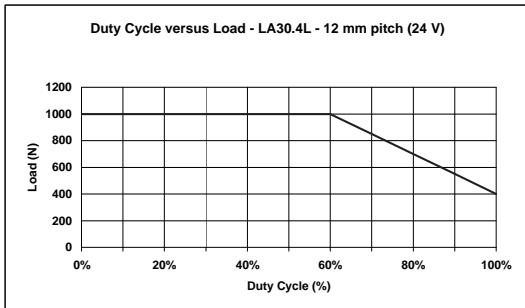

### Thrust v's Average cycles for LA30 12 mm pitch

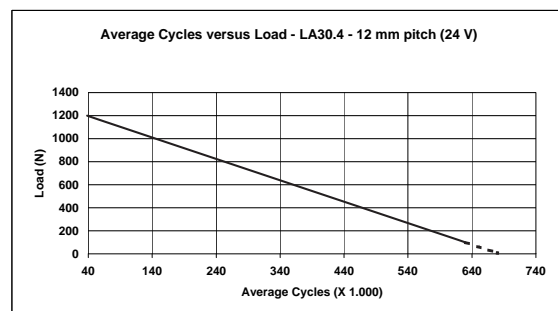
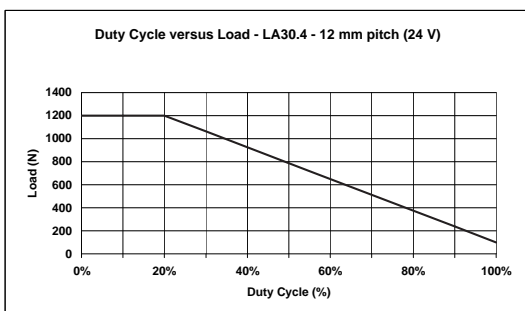
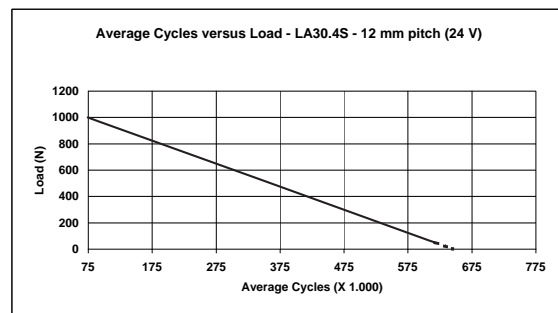
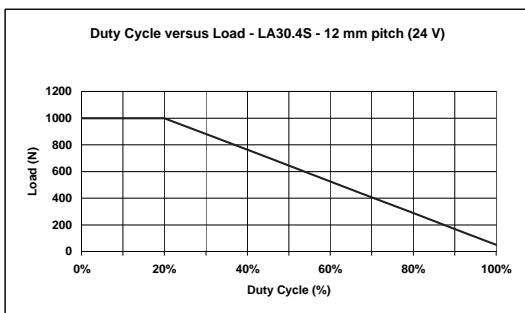
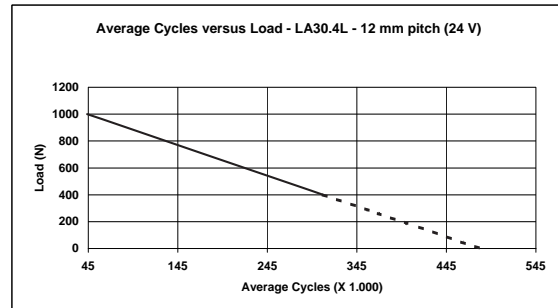

Note: The dashed lines are estimated values only.

**Precautions:**

LINAK control boxes are designed so that they will short-circuit the motor terminals (poles) of the actuator(s), when the actuator(s) are not running. This solution gives the actuator(s) a higher self-locking ability. If the actuator(s) are not connected to a LINAK control box the terminals of the motor must be short-circuited to achieve the self-lock ability of the actuator.

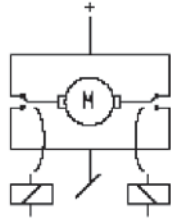
**Improved self locking ability**

The H-bridge ensures that the motor is shorted when the relays are inactive. This is necessary to improve the self-locking of the actuator.



When using LA30 with stereo jack plug be aware of the reversed direction of travel as standard.



The current supply to LINAK actuators must be cut off in case of overload when the actuators reach end position.

**Various other information:**

Noise levels:

LA30: dB(A) 50; LA30S: dB (A) 55; LA30L: dB(A) 48.

Measuring method DS/EN ISO 3746, actuator not loaded.

**Accessories for LA30:****Limit Switch**

There are two types of LINAK® limit switches, for LA30, LS and LSD.

The LSD type controls the stroke length of the actuator between two fixed end positions by cutting off the current to the motor. The LS type gives signal in two fixed end positions, but requires a control unit to stop the actuator when the micro switches are activated.

**Bellows**

- Give a better protection and therefore give a higher lifetime of the actuator
- Protects inner tube against dust and dirt
- Can be used for actuators: LA30
- Does not change the IP rating
- Available in black colour
- Ask for special folder

Please contact your nearest LINAK dealer for further details or read more on [www.linak.com](http://www.linak.com).

**Terms of use**

The user is responsible for determining the suitability of LINAK products for specific application. LINAK takes great care in providing accurate and up-to-date information on its products. However, due to continuous development in order to improve its products, LINAK products are subject to frequent modifications and changes without prior notice. Therefore, LINAK cannot guarantee the correct and actual status of said information on its products. While LINAK uses its best efforts to fulfil orders, LINAK cannot, for the same reasons as mentioned above, guarantee the availability of any particular product. Therefore, LINAK reserves the right to discontinue the sale of any product displayed on its website or listed in its catalogues or other written material drawn up by LINAK. All sales are subject to the Standard Terms of Sale and Delivery for LINAK. For a copy hereof, please contact LINAK.